

**LL1620, LL1623, LL1627**  
**Suggested connection diagram for simplified switching between different output impedance.**

**Switch between secondary connections B and C**  
(numbers refer to LL1620, LL1623, LL1627 secondary taps)

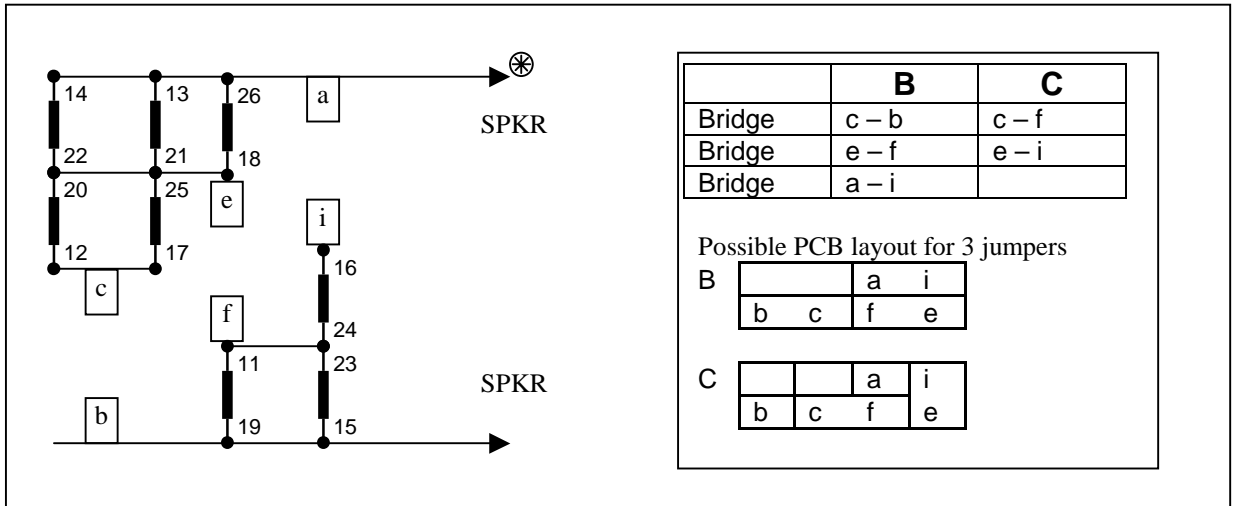

**Switch between secondary connections C and D**  
(numbers refer to LL1620, LL1623, LL1627 secondary taps)

