

Moving Coil Input Transformer LL9226XL

LL9226XL is a Moving Coil Step-Up Transformer based on (and pin compatible with) our LL9226. In the LL9226XL we have increased the core cross section about 40% to increase headroom and decrease transformer distortion. The transformer is built up from two coils, each coil with one secondary winding surrounded by two primary windings. This structure results in excellent frequency response and high immunity to surrounding magnetic fields. For flexibility, all winding ends are available on the pins. As a result, LL9226XL can be used in 1:5, 1:10 and 1:20 configurations.

The LL9226XL core is our cobalt based uncut amorphous strip core. The transformer is encapsulated in a double thickness mu metal housing.

Turns ratio: 1 + 1 + 1 + 1 : 10 + 10
Dims: (Length x Width x Height above PCB (mm)) 33 x 27 x 16 *(Note! Bigger than the LL9226)*
Pin Layout (viewed from pins side) and windings schematics:

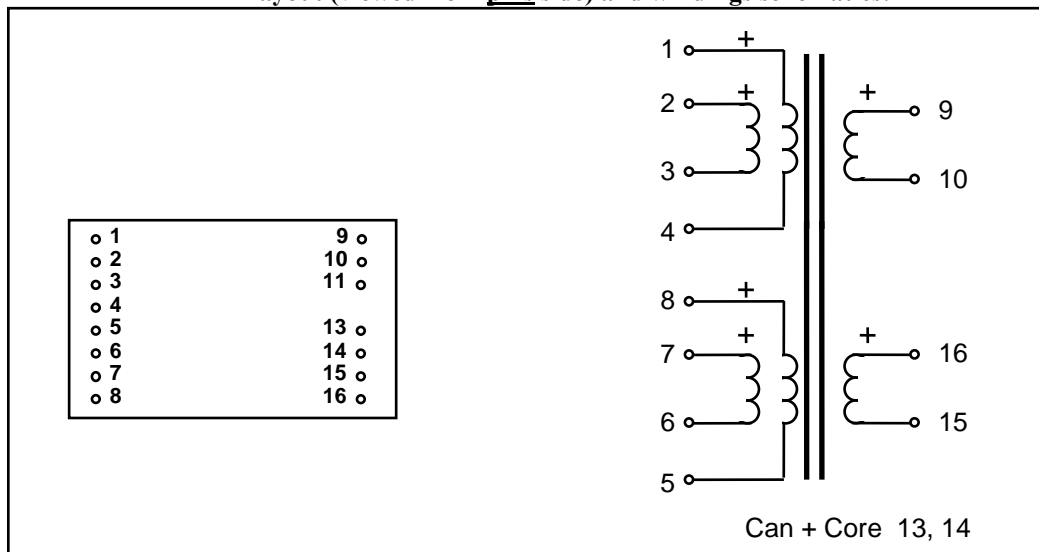

Spacing between pins:	2.54 mm (0.1")
Spacing between rows of pins:	22.86 mm (0.9")
Weight:	42 g
Rec. PCB hole diameter:	1.3 mm
Static resistance of <u>each</u> primary (average):	5.5 Ω
Static resistance of <u>each</u> secondary (average):	145 Ω
Frequency response (@ -10 dBu, Connection "A", source 50Ω , load 47 kΩ) :	7 Hz -- 70 kHz +/- 1 dB 4 Hz -- 90 kHz +/- 1.5 dB
Distortion (primaries connected in series, source impedance 40Ω) :	< 0.1% @ -2 dBu, 50 Hz
Primary no load impedance @ 0 dBu, 50 Hz, all in series:	5 kΩ typically
Core / Can:	Cobalt amorphous strip core / Double thickness mu metal can
Isolation between windings / between windings and core:	3 kV / 1.5 kV

Turns ratio and suggested use at different termination alternatives. Termination alternatives are shown on the next page			
Termination Alternative	Turns ratio	Copper Resistance prim/sec	Suggested use for best frequency response
A	1:5	22 Ω / 290 Ω	MC cartridge < 100 Ω
B	1:5	5.5 Ω / 70 Ω	Not recommended
C	1:10	5.5 Ω / 290 Ω	MC cartridge < 50 Ω
D	1:10	1.4 Ω / 70 Ω	Not recommended
E	1:20	1.4 Ω / 290 Ω	MC cartridge < 25 Ω

Application hint:
As the LL9226XL does not have Faraday shields, both sides of the transformer should have a common ground reference.

R200529



LL9226XL Termination Alternatives (Left side is input if not stated otherwise) (Pins side view)

