

## Transformer splitting unit DIN1581XL

DIN1581XL is a ready-to-use transformer unit with screw terminals. DIN1581XL can be used for galvanic isolation, balanced/unbalanced conversion and splitting 1 direct -> 1 direct + 2 isolated output.

As indicated in the name, the unit is designed to fit on DIN rail (EU EN50022, US TS35) profiles, but it also has facilities for screw mounting. The internal transformer is our general purpose LL1581XL

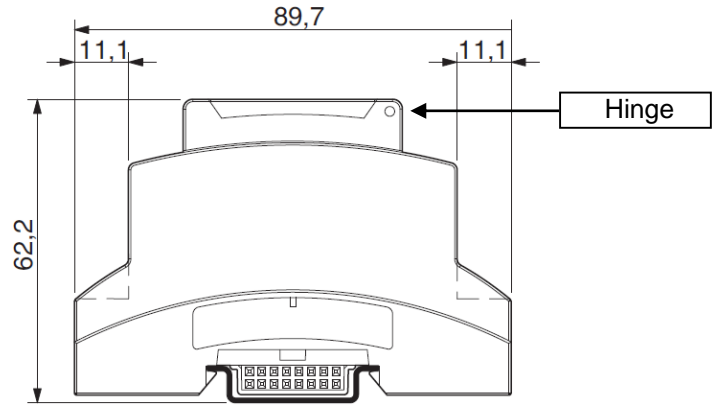

----- Suggested connection -----

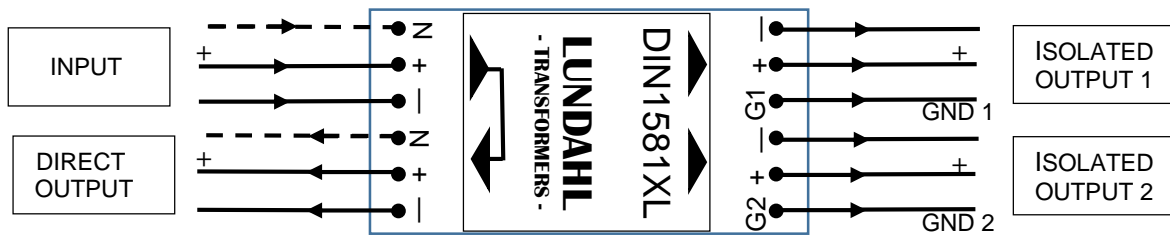

----- Technical details -----

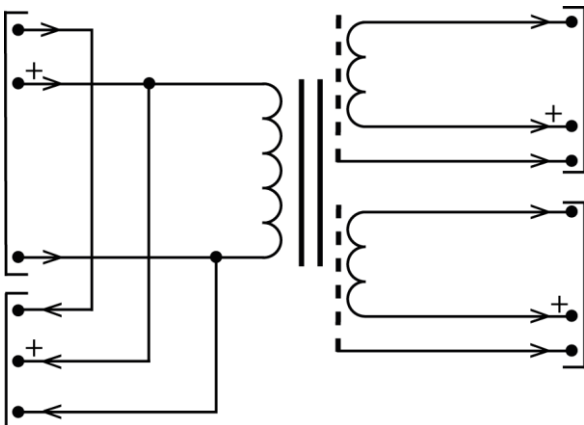

<b>Transformer static resistance primary + secondary:</b>	60Ω , each channel
<b>Core:</b>	Mu metal lamination core
<b>Max signal level (THD less than 1%):</b>	+13 dBu @ 50 Hz
<b>Frequency response @ 0 dBu (source 150Ω, load 10kΩ)</b>	10 Hz - 100 kHz +/-1 dB
<b>Distortion (THD) at 50 Hz (source 150Ω )</b>	< 0.2 % @ 50 Hz, for all signal levels -40 through +8 dBu
<b>Loss across transformer with load 10kΩ</b>	0.2 dB
<b>Isolation between input and output sides:</b>	1 kV

R160523 PL

